

Kröber

MEDIZINTECHNIK

Technical Information

Kröber O2

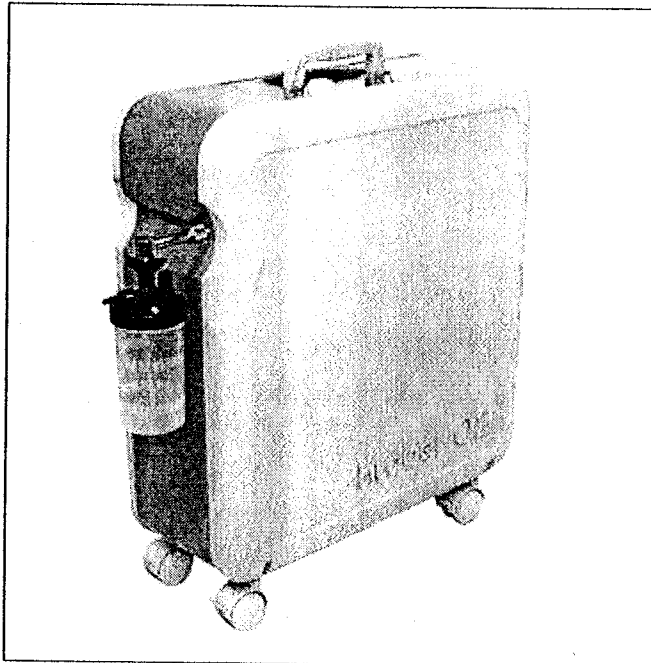

© Kröber Medizintechnik GmbH
Salzheck 4
D-56332 Dieblich

Tel.: +49 (0) 2607 9404 0
Fax: +49 (0) 2607 9404 22

E-Mail: info@kroeber.de
Internet: www.kroeber.de

Rev.: 1

Table of contents

1 Preliminary remarks	5
1.1 General information	5
1.2 Warranty	5
2 Service	7
2.1 Kröber O2	7
2.1.1 Opening the Kröber O2	7
2.1.2 Closing the Kröber O2	9
2.2 The functional unit	10
2.2.1 De-installing the functional unit	11
2.2.2 Installing the functional unit	13
2.3 The fan	17
2.3.1 Disassembling the fan	17
2.3.2 Installing the fan	19
2.4 Control PCB	21
2.4.1 Uninstalling the control PCB	21
2.4.2 Installing the control PCB	26
2.5 The compressor	30
2.5.1 Removing the compressor	30
2.5.2 Installing the compressor	33
3 Maintenance procedures	35
3.1 Safety inspection, annually	35
3.2 Exchanging the filters	35
3.2.1 Coarse dust filter	35
3.2.2 Device inlet filter	36
3.2.3 Device outlet filter	36
4 Recommendations for re-processoing	38
4.1 without change of the patient	38
4.2 with change of the patient	38
5 Description of functions	39
5.1 General information	39
5.2 Control PCB	40
5.3 flow schematics	41

5.4 Alarms.....	42
5.4.1 Alarm priorities	42
5.4.2 Alarm categories	43
5.5 Symbols.....	47

Kröber O2

Preliminary remarks

Kröber

2 Service

2.1 Kröber O2

2.1.1 Opening the Kröber O2



WARNING! Danger of electric current!

Before opening, the unit must be switched off and disconnected from the mains supply.



NOTE!

For easy access to the unit, place the unit on a clean support. Empty and remove the installed humidifier first.

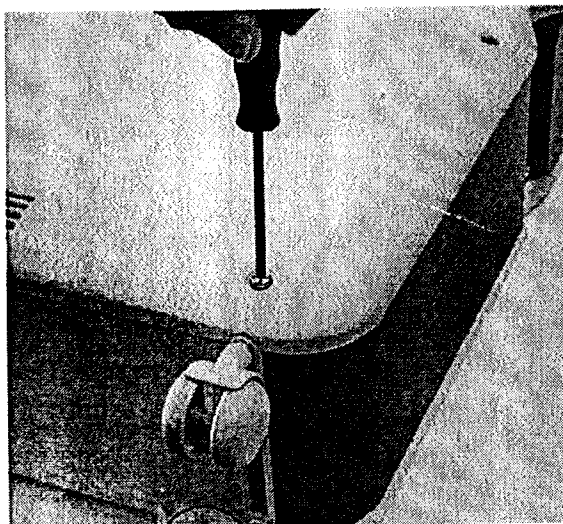
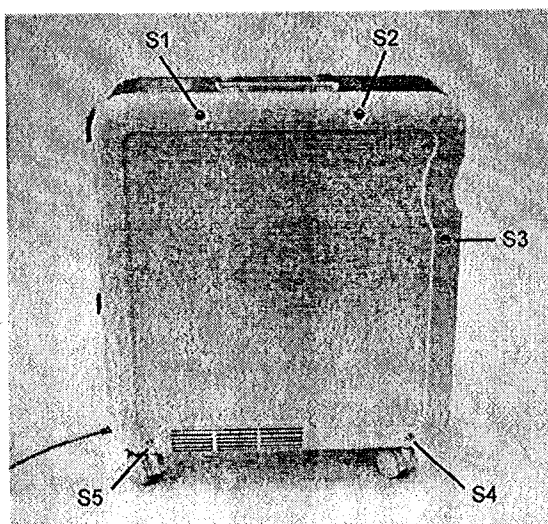

1. Unscrew S1 to S5.
2. Carefully remove grey housing.
3. Carefully remove the blue service flap and store it separately.

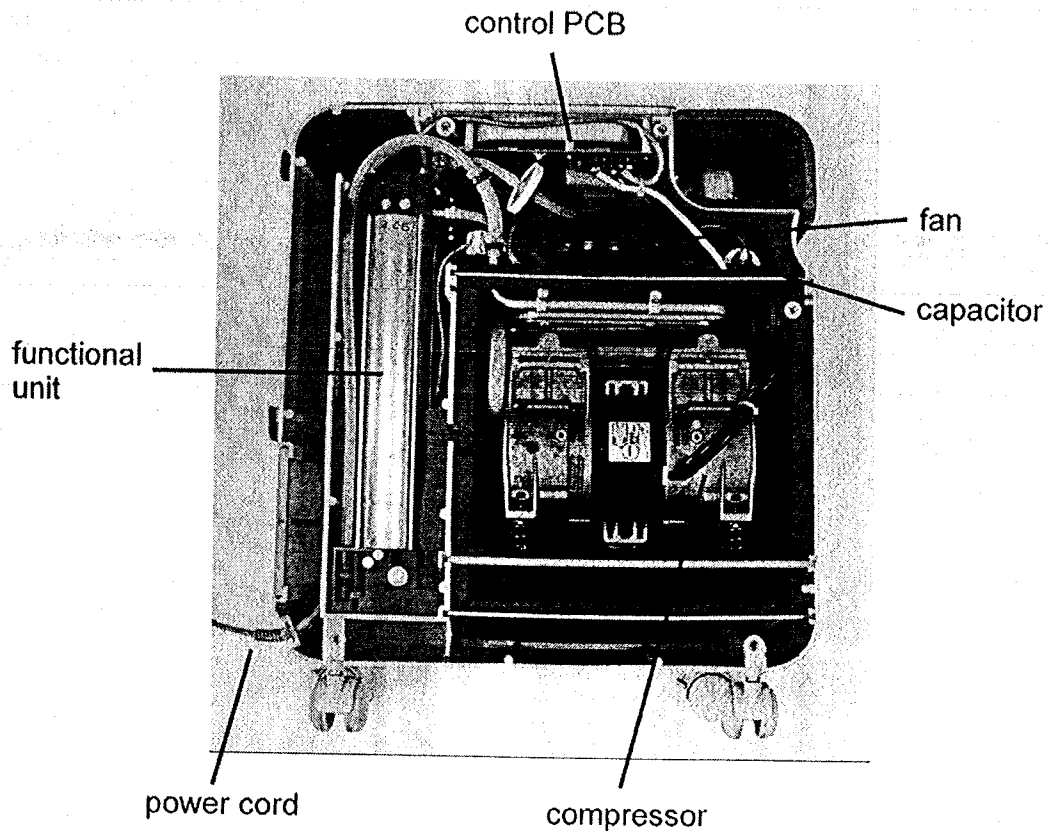

4. In the opened unit there are the subassemblies:

- a. control PCB
- b. functional unit
- c. compressor
- d. fan

and the components

- e. capacitor
- f. power cord

2.1.2 Closing the Kröber O2



Closure of the Kröber O2 can be easily done with a device placed on the side.

1. Carefully re-install the grey housing cover and pay attention for a correct fit.
2. Insert all housing screws; screws down S4 und S5, then all other screws

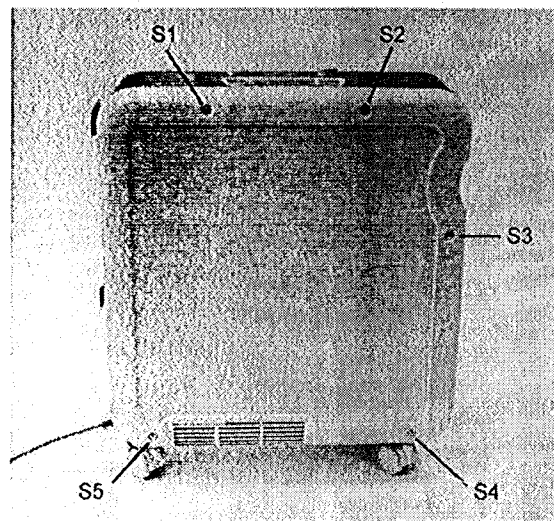

3. Carefully feed the blue service flap with both lateral noses into the corresponding support in the main housing body. Gently stretch the housing.



4. Screw all five housing screws hand-tight.
5. Install the coarse dust filter cover in the back of the Kröber O2.

2.2 The functional unit

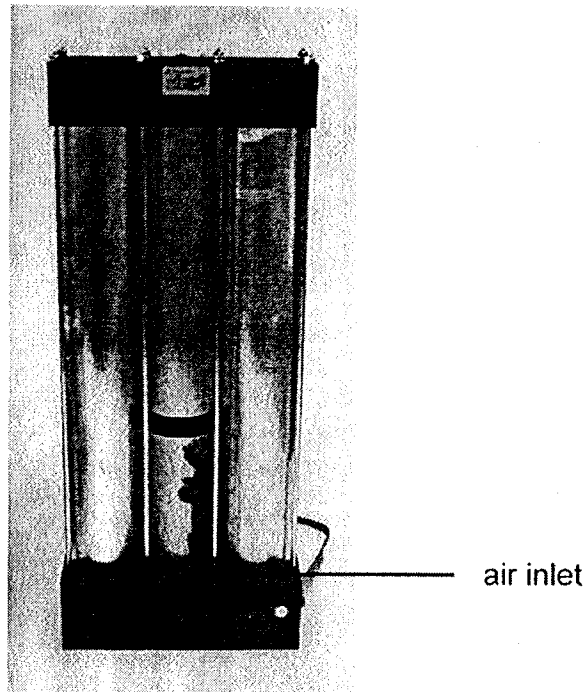
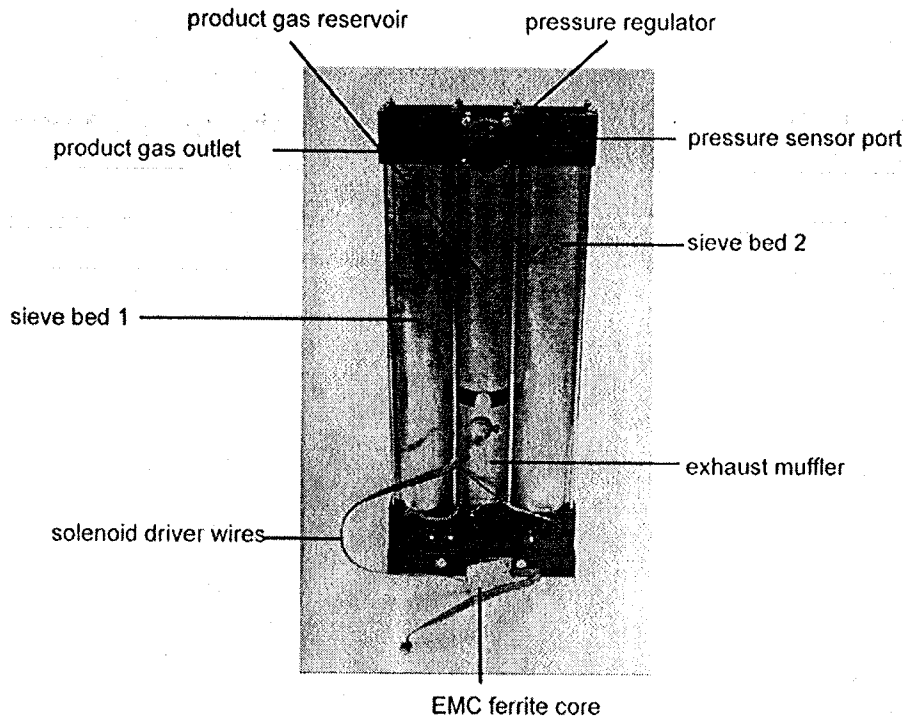

2.2.1 De-installing the functional unit

1. Remove the red connector of the solenoid wire from the control PCB.

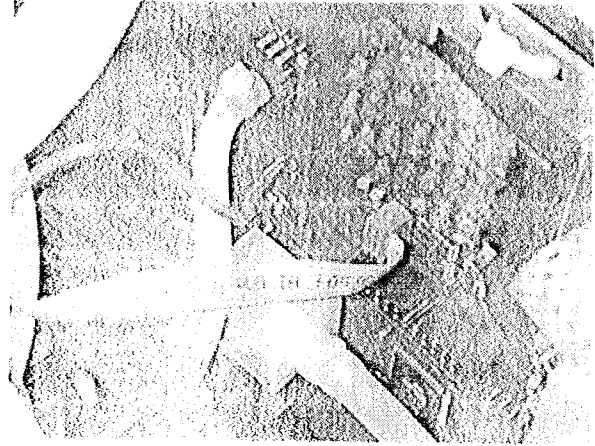

2. Dismantle the EMC-core using an edge cutter.

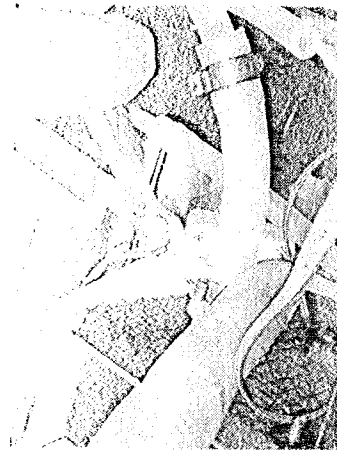

3. Press the rim of quick connect at the air inlet of the functional unit smoothly down and pull out the tubing.

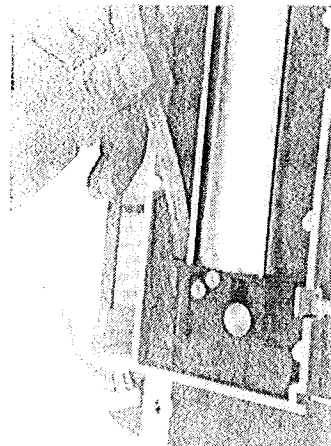

4. Push the rim of the quick connect hose at the gas outlet of the functional unit smoothly and pull out the tubing.

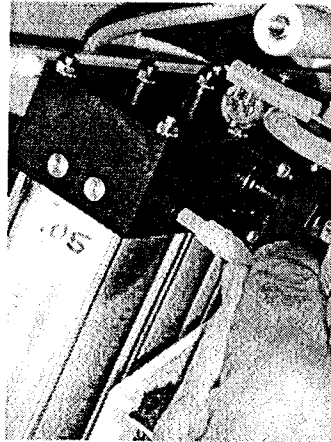

5. Lift half-way the functional unit.

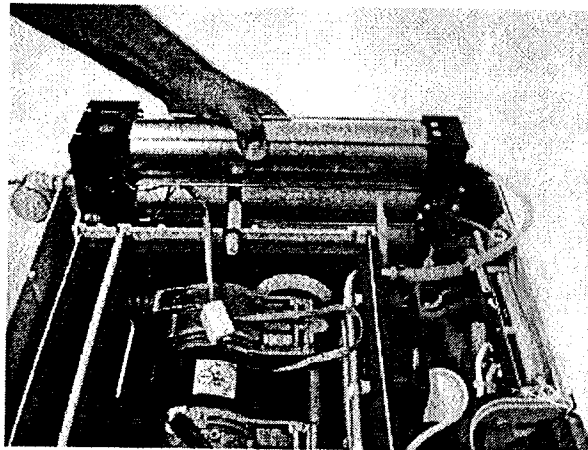

6. Push the rim of the quick connect hose at the pressure outlet of the functional unit smoothly and pull out the tubing.

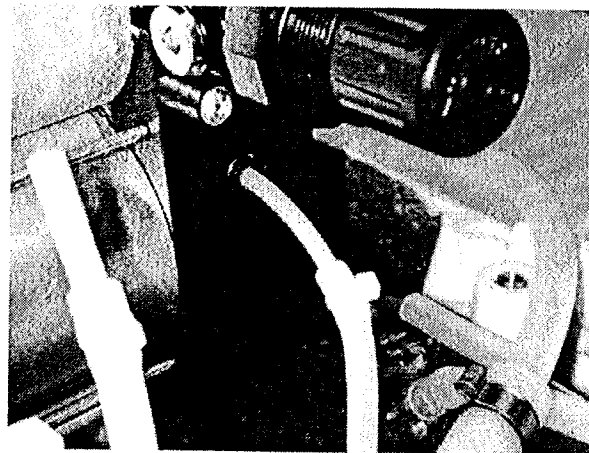

7. Take out the functional unit completely.

2.2.2 Installing the functional unit

1. Remove the three protection caps from the inlets and outlets of the functional unit.
2. Guide the quick connect of the pressure sensor into the corresponding port of the functional unit.

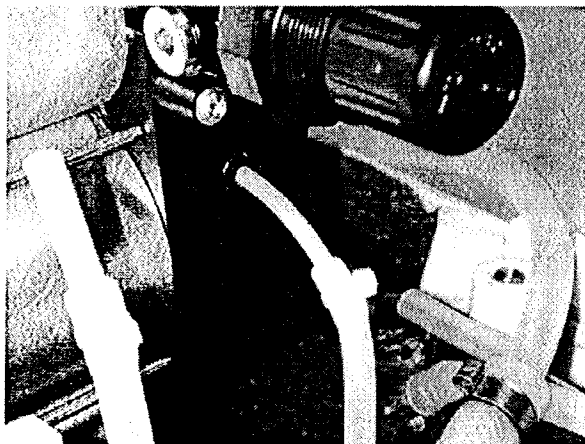

3. Insert the functional unit carefully into the slot.

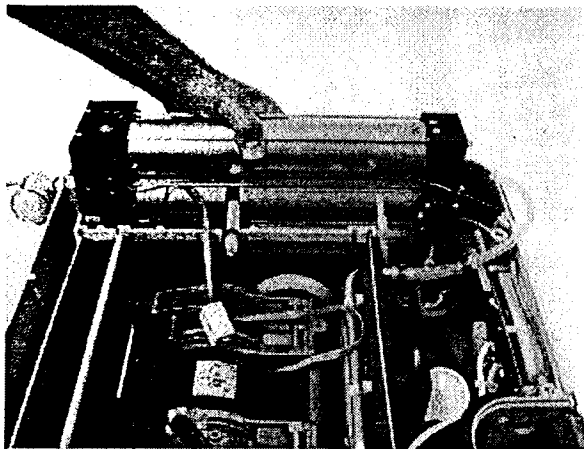

4. While inserting, pay attention to properly insert the exhaust muffler into the corresponding slot.

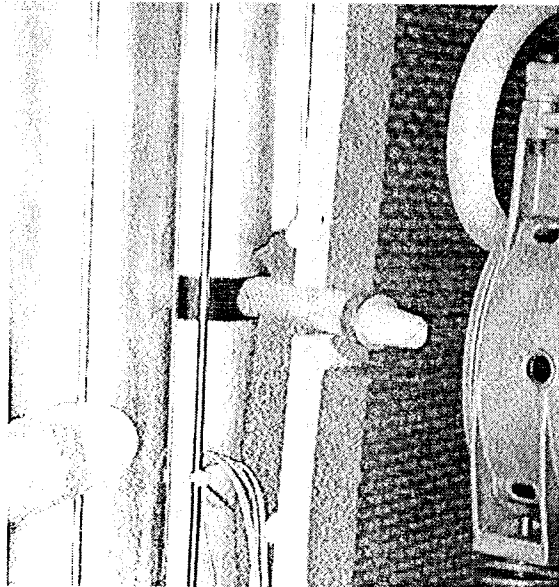

5. The exhaust muffler is in the correct end position if it is facing the compressor.

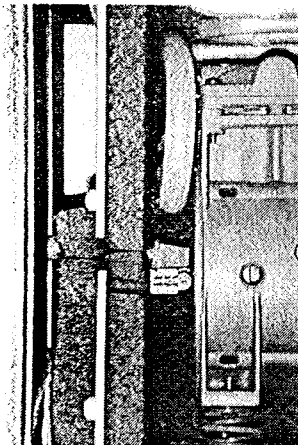

6. In the correct end position, the head of the functional unit is held by a stop (s. circle).

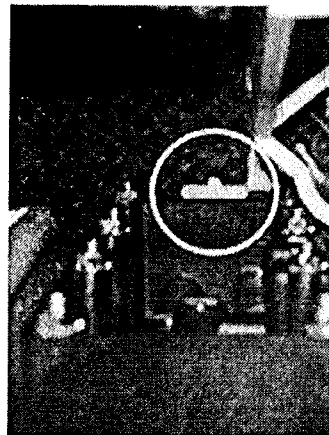

7. Attach the hose of the product gas outlet as far as it will go.

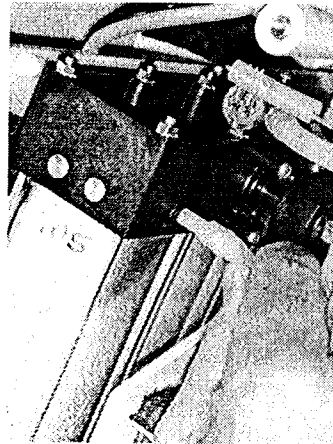

8. Install the quick connect hose as far as it will go into the air inlet of the functional unit.

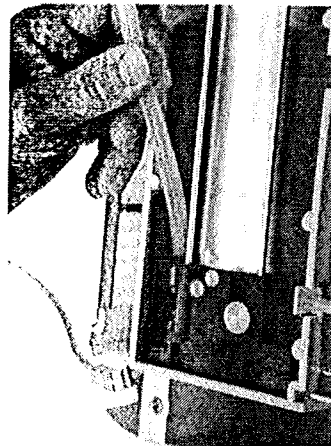

9. Fixate the EMC filter with a cable tie at the outlet hose of the air-cooler coil.

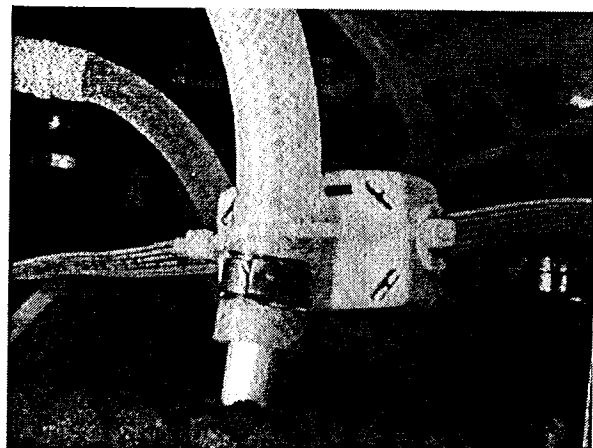

10. Attach the red connector of the solenoid driver cable with the corresponding connector on the control PCB. Check polarity. The pin should be pointing towards the black box header.

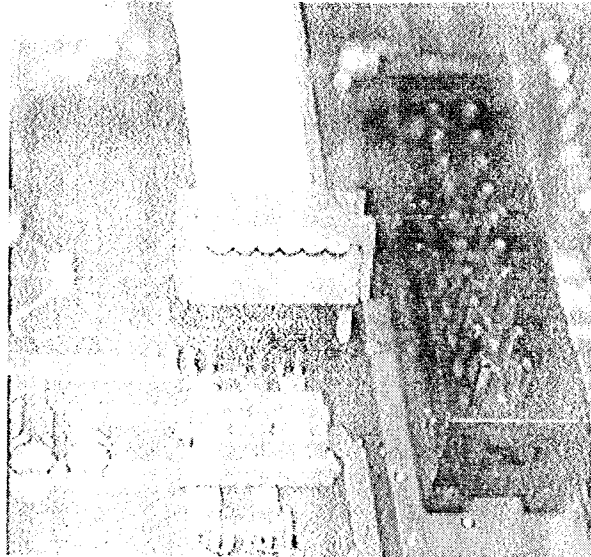

11. Install the connector as far as it goes.

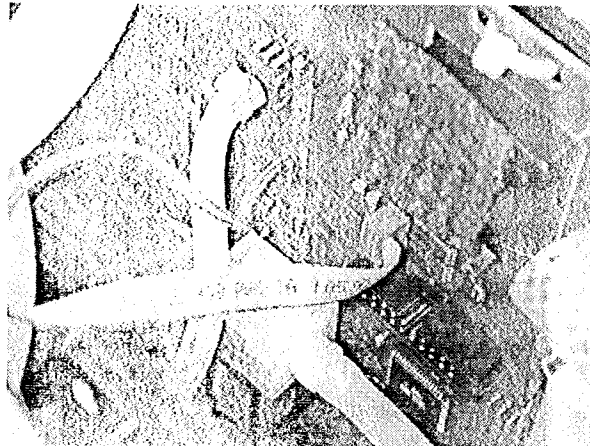

12. Check piping and wiring for proper laying without kinking or pinching.

2.3 The fan

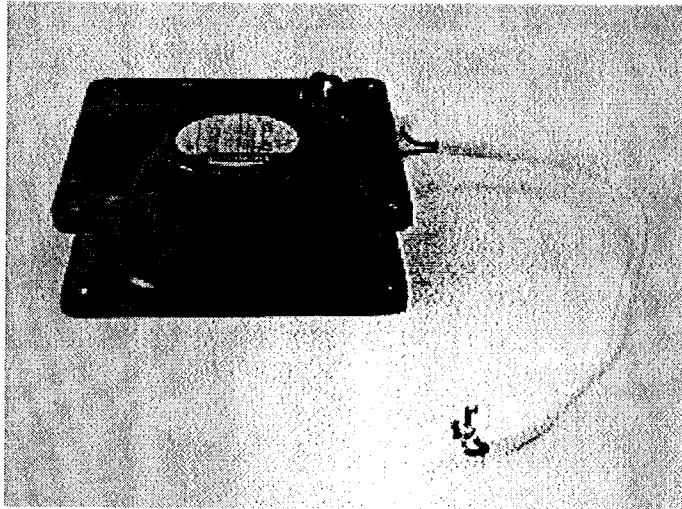

2.3.1 Disassembling the fan

1. Unfasten both wires of the fan at the terminal block on the control PCB.

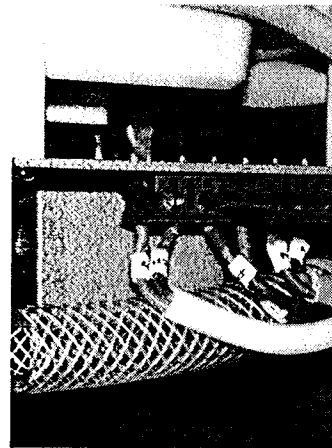

2. Cut the cable tie of the cable harness with an edge cutter.

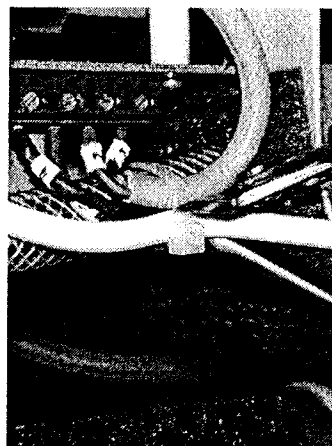

3. Pull out the complete assembly (fan and air-cooler) half-way.

If necessary unfasten the EMC-filter from the air-cooler.



Note!

Eventually re-adjust compressor wire and thereby release any tension!

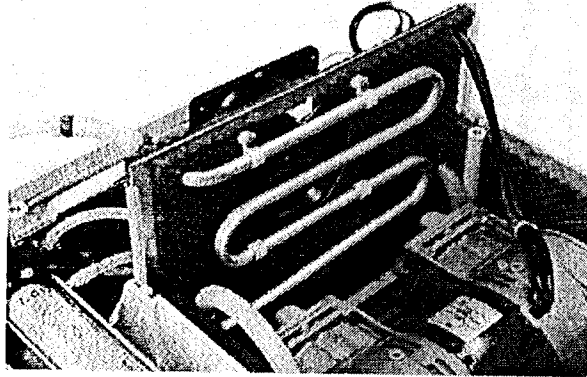

4. Unfasten the 4 mounting screws of the fan.

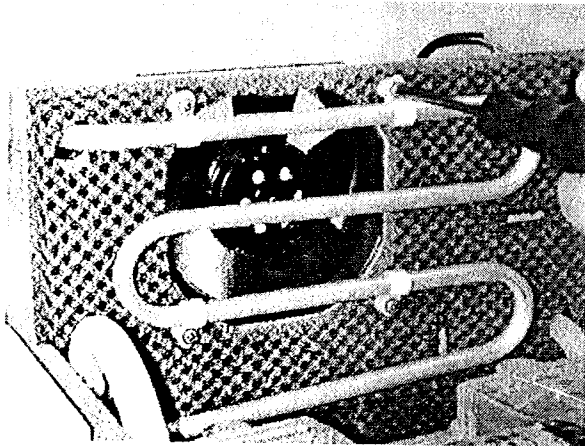

5. Do not unscrew the screws completely, leave them in the thread.

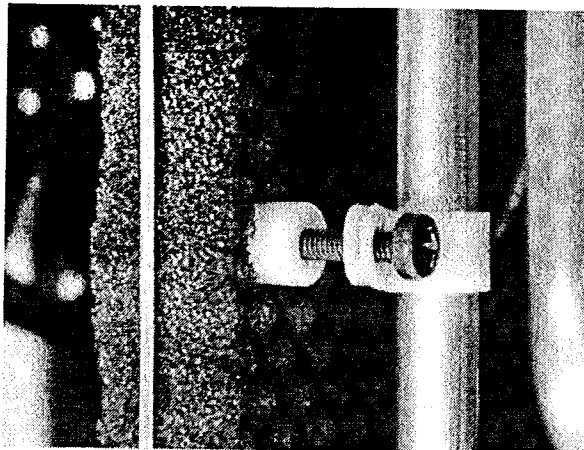

6. Remove the fan out of the unit.

2.3.2 Installing the fan

1. When installing the fan, pay attention that the imprinted arrow (indicating the air flow) points towards the steel plate.

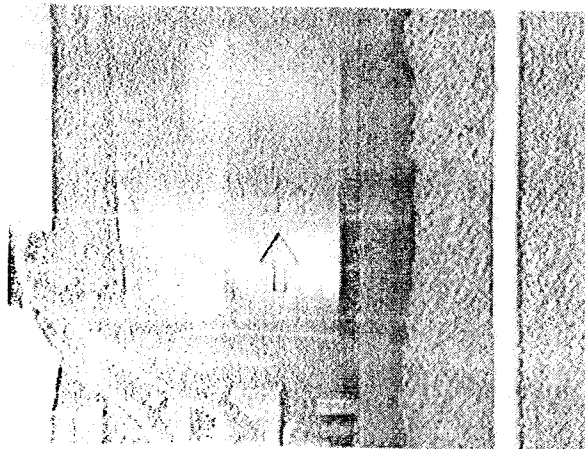

2. Screw the four mounting screws hand-tight.

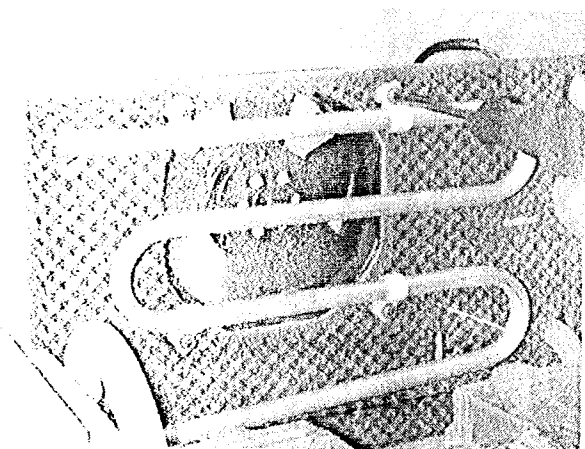

3. Push the fan support evenly back into the slots.

NOTE!

Pay attention that the silicone profiles also slide into the slots.

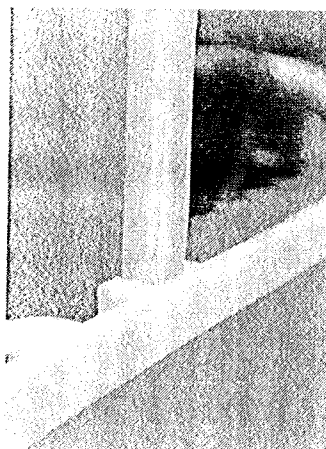

4. If necessary, re-adjust the position of the compressor wires.

5. If necessary re-fasten the EMC-filter with a cable tie at the silicone hose of the air-cooler outlet.

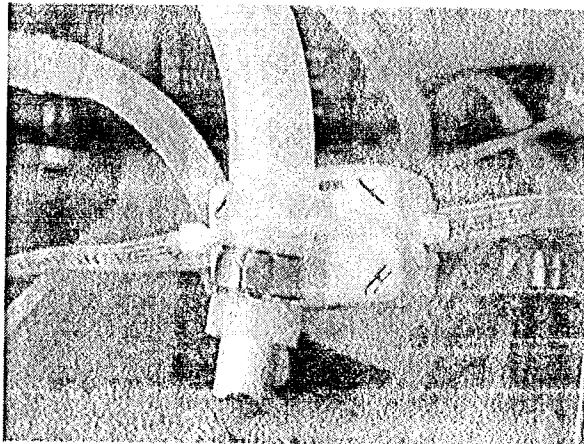

6. Re-install the leads (no. 5 and 6) of the fan in the terminal block pos. 5 and 6.

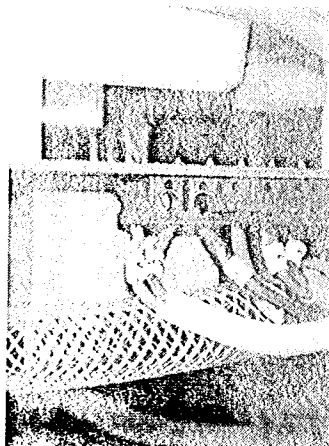

7. Bind together the cable harness and the hose with a cable tie.

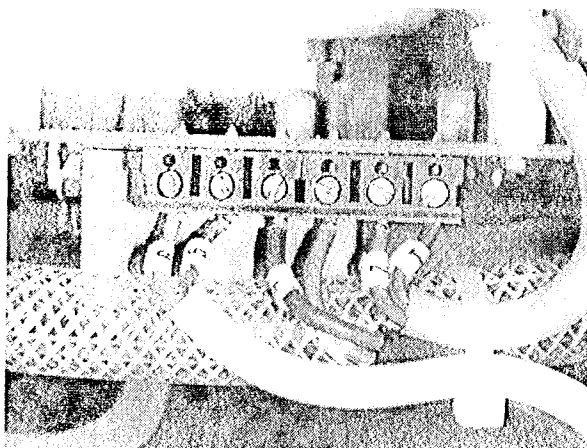

2.4 Control PCB

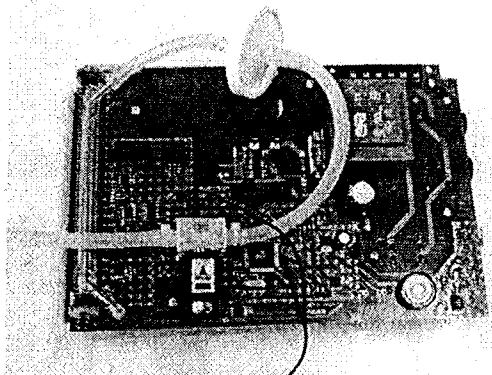

2.4.1 Uninstalling the control PCB



Warning!

The control PCB contains sensitive electronic integrated circuits. Observe ESD (electrostatic discharge) precautions when disassembling and reassembling the Kröber O2 and when handling any of the components of the Kröber O2!

1. Disconnect all leads at the terminal block of the control PCB.
To exclude mix-ups, the leads are numbered serially:
 - no. 1 and 2: mains voltage supply
 - no. 3 and 4: compressor
 - no. 5 and 6: fan

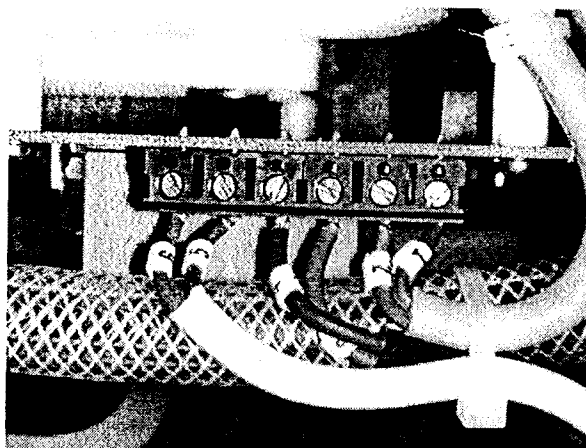

2. Cut the cable tie of the power cord.

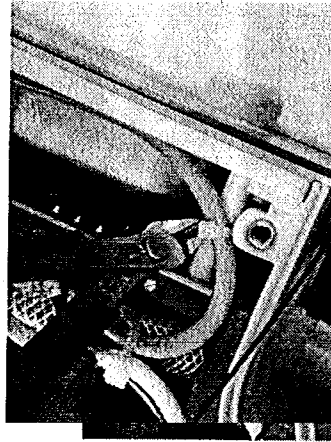

3. Bend all hoses and the cables aside.

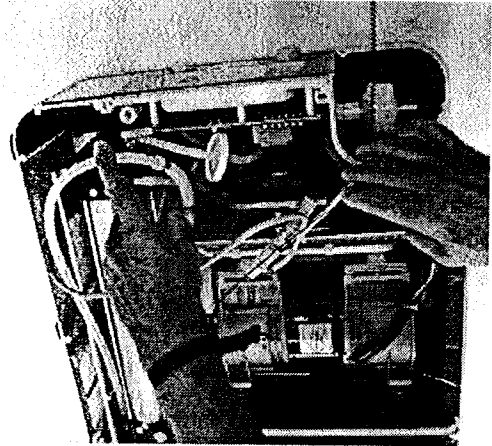

4. Pull out the assembly of the control PCB and control panel by half way.

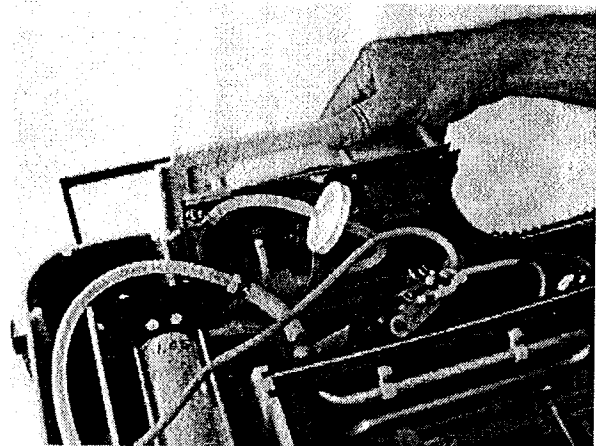

5. Pull the connecting hose off the pressure sensor.

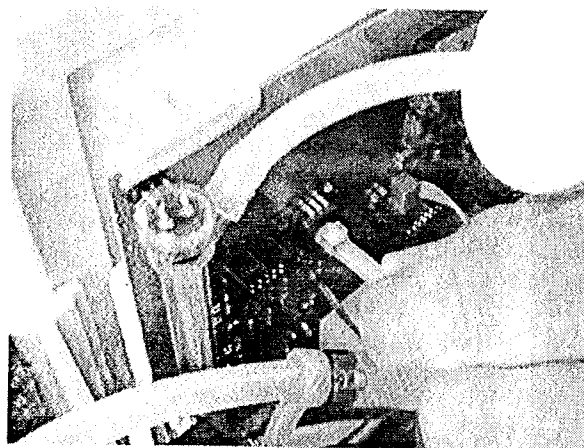

6. Extract the control PCB completely, but do not put it down.

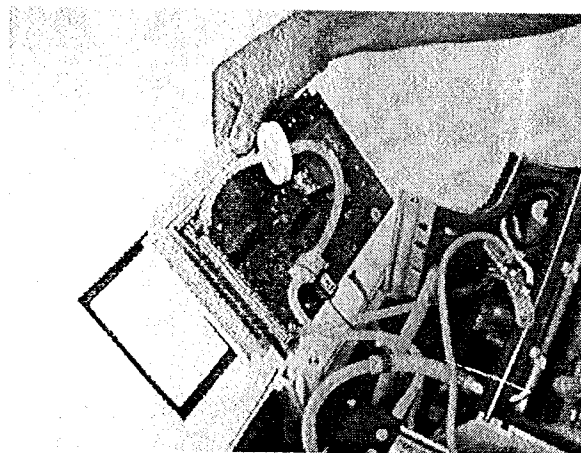

7. Disconnect the silicone hose from the multifunctional sensor.

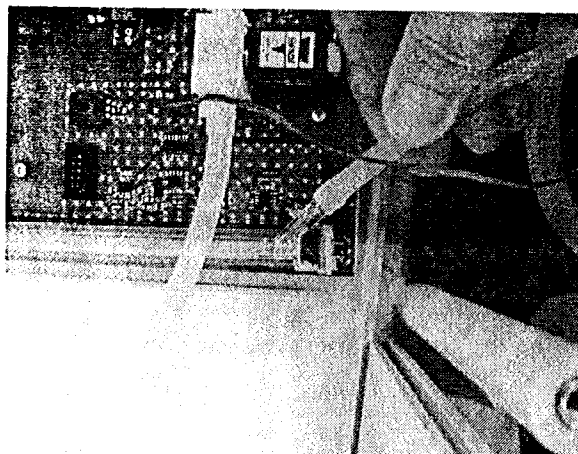

8. Pull the temperature sensor out of the compressor compartment.

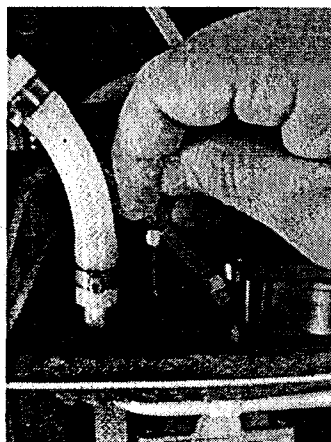

9. Remove the control PCB including plug-in panel entirely.

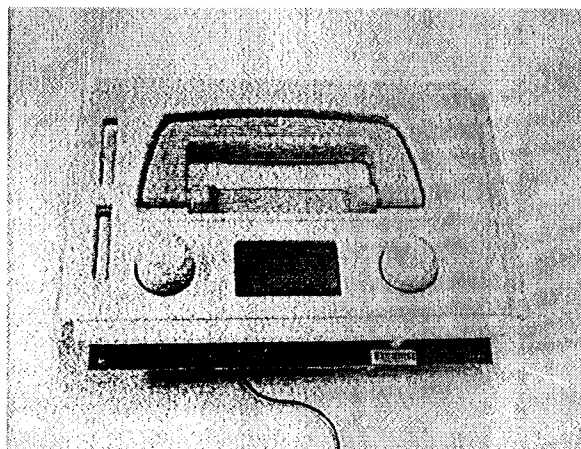

10. Remove both control elements by pulling them off.

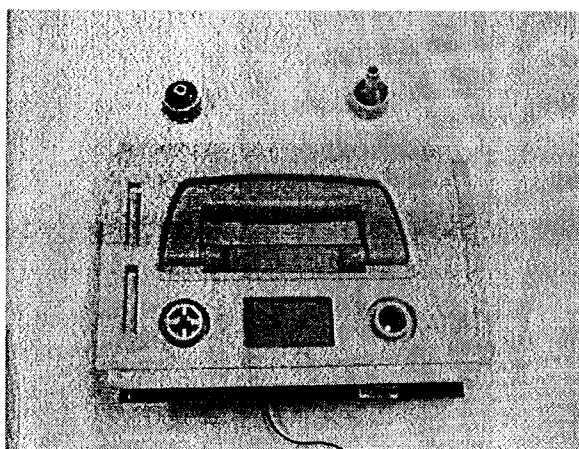

11. Flip the control PCB and unscrew the 6 mounting screws.

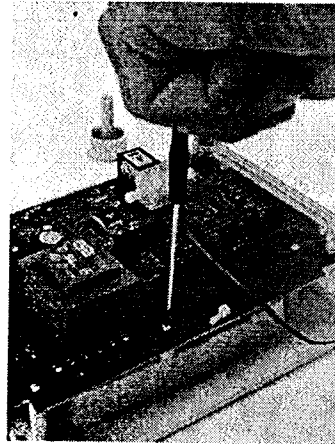

12. Store the control PCB separately and ESD-protected.

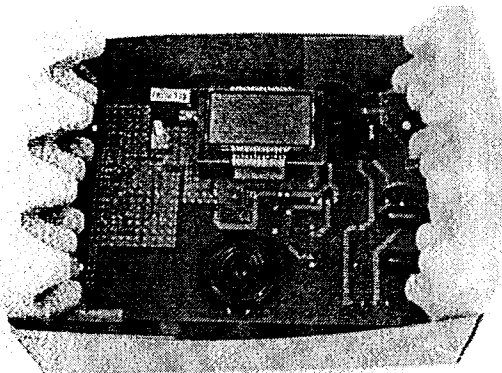

2.4.2 Installing the control PCB



Warning!

The control PCB contains sensitive electronic integrated circuits. Observe ESD (electrostatic discharge) precautions when disassembling and reassembling the Kröber O2 and when handling any of the components of the Kröber O2.

1. Remove the transport packaging from the control PCB.

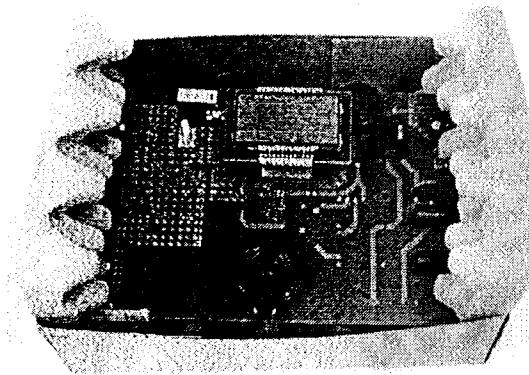

2. Mount the control PCB with 6 mounting screws to the front panel.

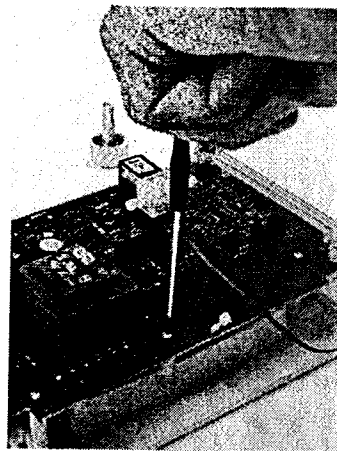

3. Flip the assembly. Fit both control buttons on the corresponding components.

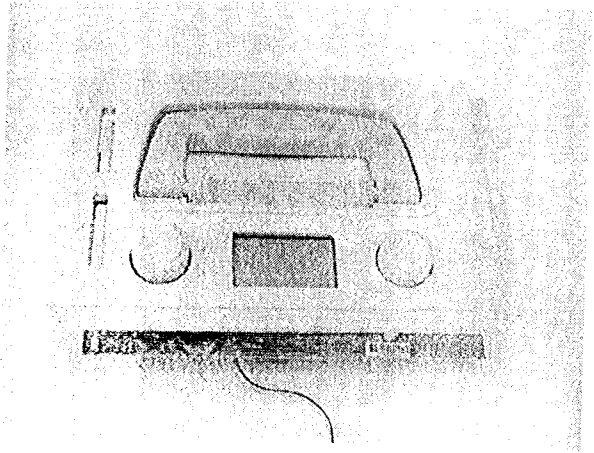

4. Uncoil entirely the temperature sensor wire and thread it through the corresponding hole into the compressor compartment.

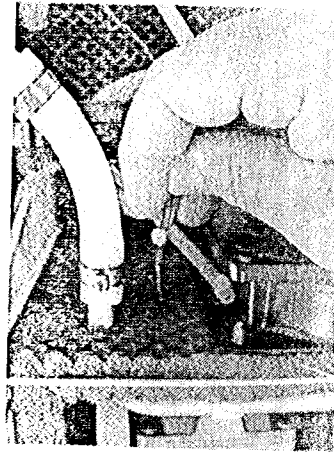

5. Slide the control PCB including panel and blue plexiglass panel into the slots by half and hold it there.

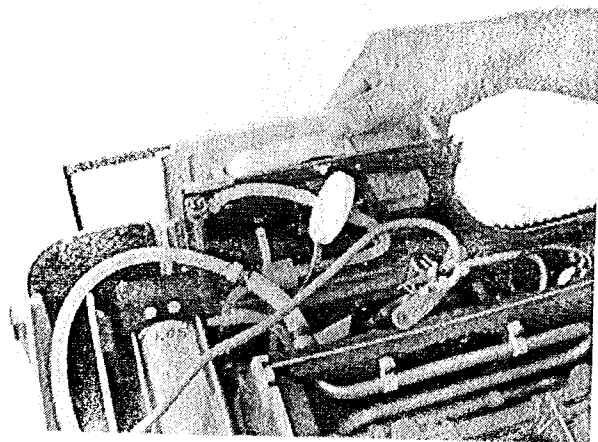

6. Re-install the silicone hose on the unconnected port of the multifunctional sensor.

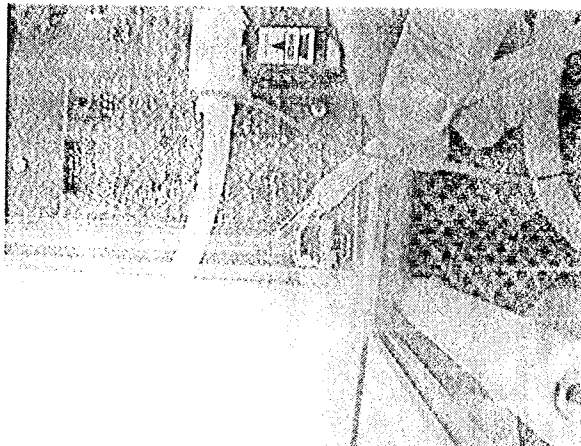

7. Re-install the pressure sensing hose on the pressure sensor port.

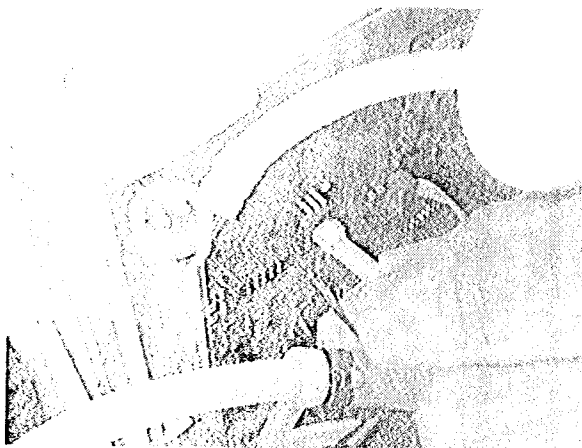

8. Push the control PCB as far as it goes.

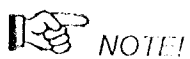

NOTE!

Pay attention for a proper fit of the blue card with safety directions!

9. Fasten the power cord with a cable tie at the dome (right top in the figure).

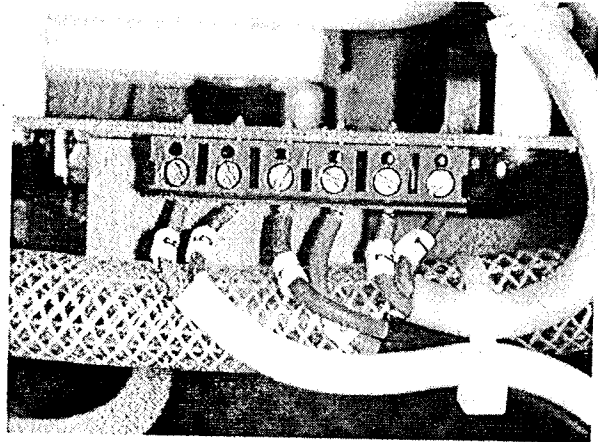

10. Re-install all leads at the terminal blocks on the control PCB.

To exclude mix-ups, the leads are numbered serially:

- no. 1 and 2: mains voltage supply
- no. 3 and 4: compressor
- no. 5 and 6: fan

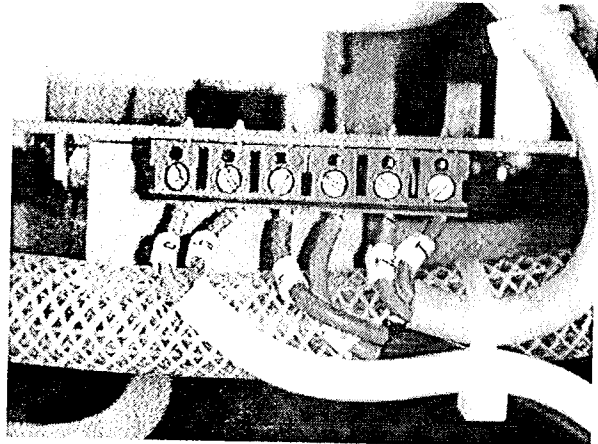

2.5 The compressor

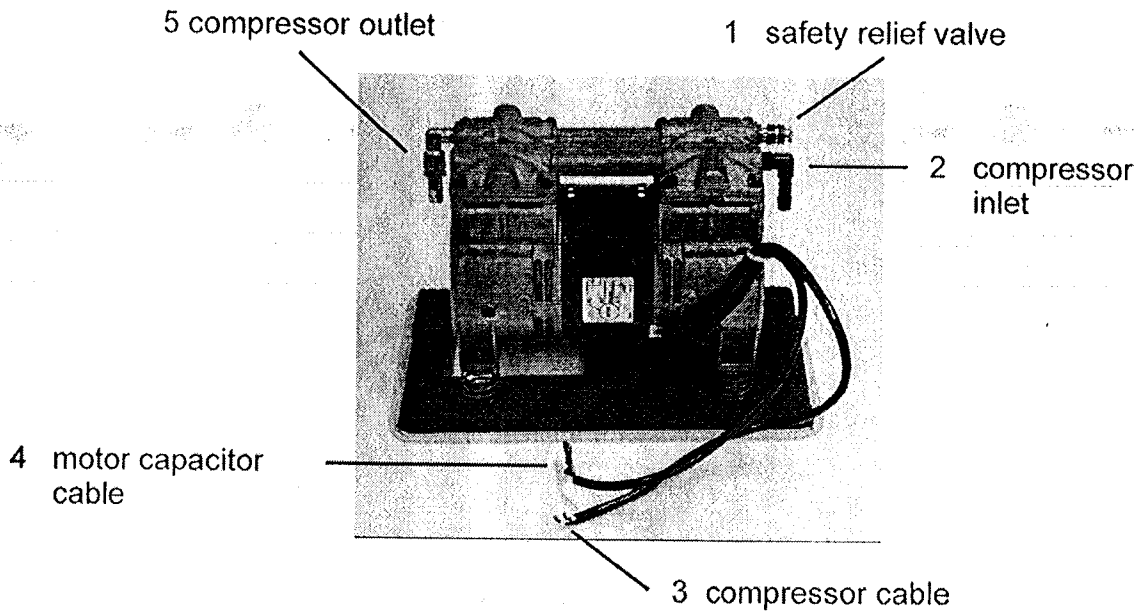

2.5.1 Removing the compressor

1. Disconnect leads no. 3 and 4 (compressor) at the terminal block of the control PCB.

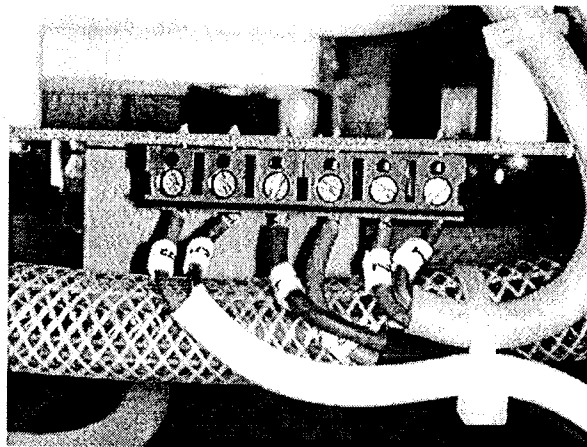

2. Cut the cable tie at the cable harness.

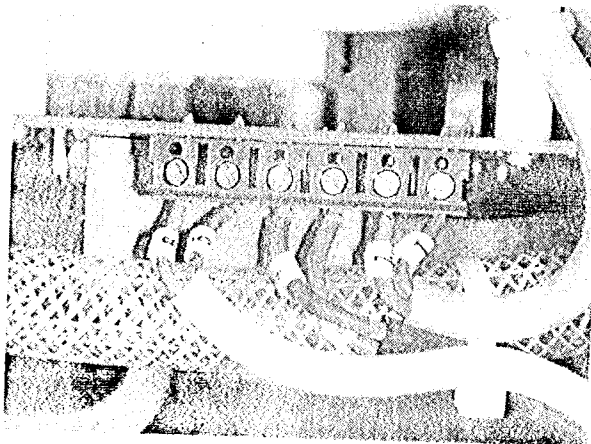

3. Pull the compressor cable through the grommet of the steel plate.

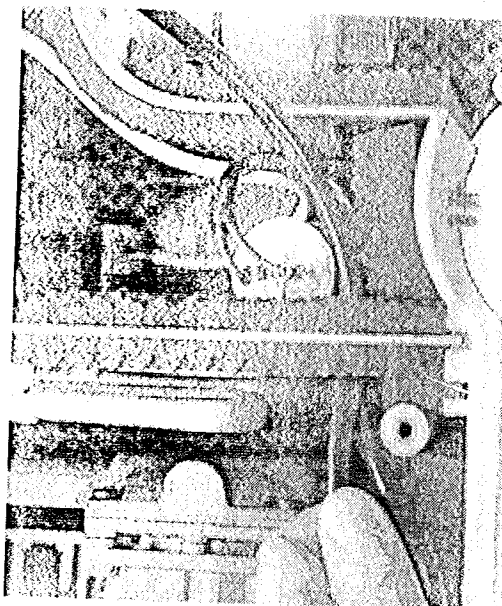

4. Disconnect connecting cable of the motor capacitor from the motor capacitor.
5. Pull back connecting cable through the grommet.

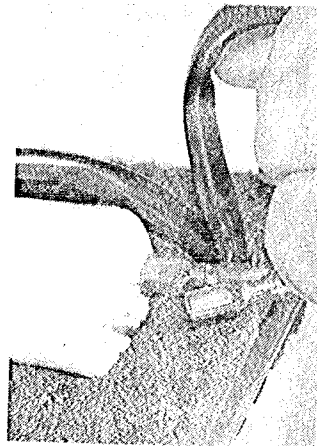

6. Pull compressor including support plate half-way out of the slots and hold it.
7. Open the clamp at the pressure outlet of the compressor using a screw driver and pull the hose from the nipple.

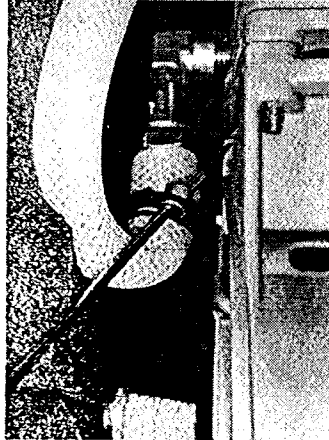

8. Also pull the hose from the compressor inlet nipple.

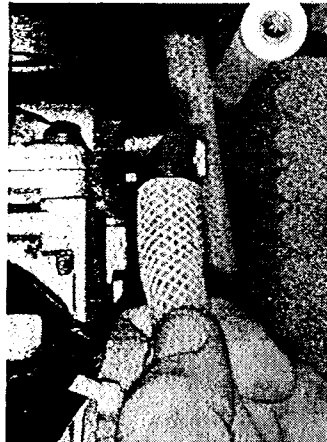

9. Completely remove compressor including support.

2.5.2 Installing the compressor

1. Slide compressor including support half-way down..
2. Put a new clamp over the hose of the pressure outlet of the compressor.
3. Feed the pressure outlet hose over the stainless steel nipple.
4. Secure the connection by pinching the clamp.

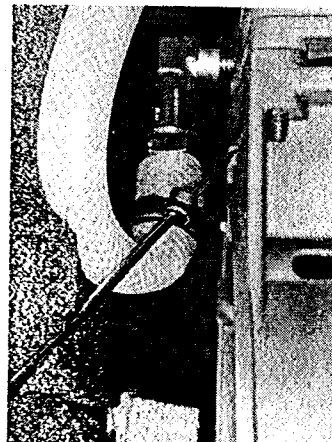

5. Feed the air inlet hose over the grey plastic nipple.



6. Push the compressor (including support) gently back as far as it goes.

NOTE!

Pay attention that the silicone profiles also slide into the slots.

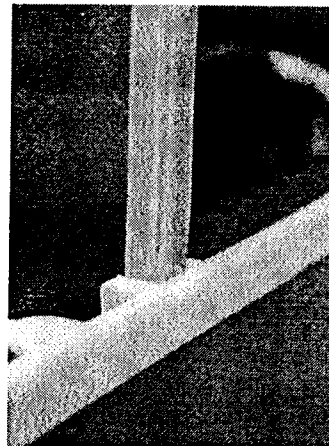

7. Feed the compressor wires through the grommet.
8. Also feed the motor capacitor wires through the grommet.

NOTE!

Because of the lugs, feed each wire separately through the grommet.

9. Connect the capacitor with the connection wires.

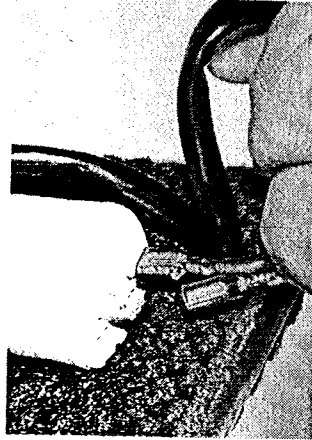

10. Feed the compressor wires to the control PCB. Connect labelled leads (no. 3, 4) with the corresponding terminal block (3, 4) on the control PCB.

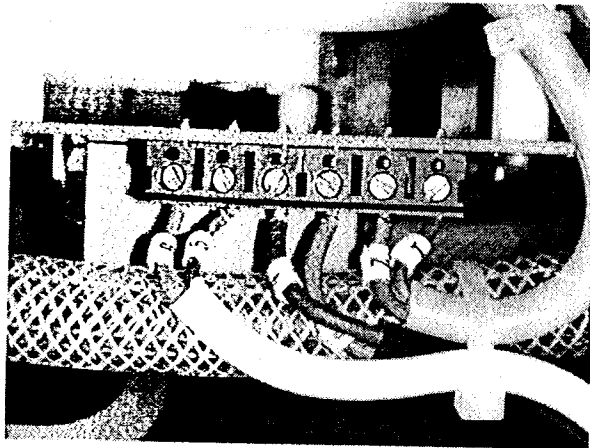

11. Secure the whole cable harness with a cable tie at the hose.

3 Maintenance procedures

3.1 Safety inspection, annually

If the KröberO2 is used in the home, the manufacturer specifies an annual safety inspection.

- determination and documentation of the oxygen concentration.
- determination and documentation of the oxygen flow.

3.2 Exchanging the filters

3.2.1 Coarse dust filter

Time interval: if required, at least monthly.

1. Open the coarse dust filter cover in the rear of the Kröber O2.

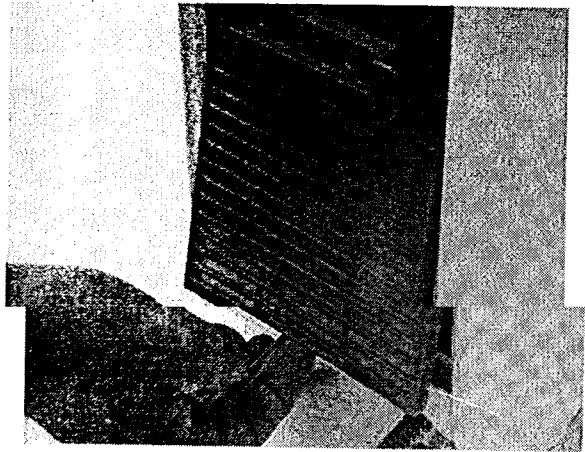

2. Pull out the old filter.
3. Dispose of the old filter.
4. Thread the new filter fleece into the holder.

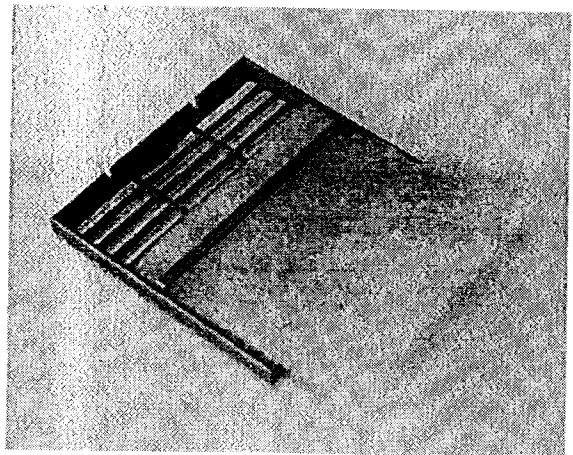

5. Re-install the filter cover in the back of the Kröber O2

3.2.2 Device inlet filter

Time interval: annually by the service technician, not later than after 5000 operation hours.

The device inlet filter is located behind the service lid and protects the compressor of contamination.

1. Open the service flap.

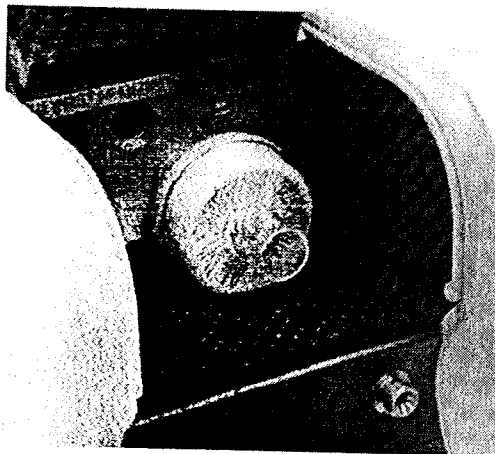

2. Pull out the old filter by careful rotations.
3. Dispose of the old filter.
4. Install the new filter element by careful rotations.
5. Close the service flap.

3.2.3 Device outlet filter

The device outlet filter resides in the interior of the Kröber O2 before the gas exit and filters particles $>8\mu$.

1. Open the KröberO2
2. Remove both silicone hoses at the device outlet filter and remove the old, used device outlet filter.

(see chapter 2.1.1)

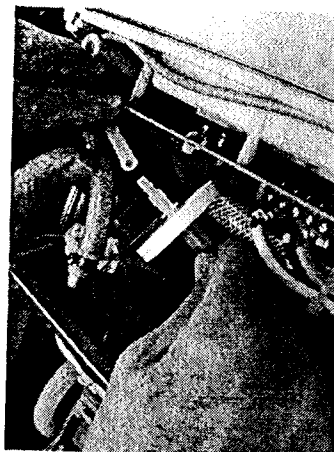

3. Dispose of the old filter.

4. Install the new filter. Pay attention to the direction of the flow. The visible arrow on the filter should direct away from the solenoid towards the multifunctional sensor.
5. Close the Kröber O2.

4 Recommendations for re-processing

for accessories and consumables during the annual maintenance service

4.1 without change of the patient

humidifier (reusable):	clean and disinfect
humidifier (non-reusable):	dispose
holder for humidifier:	clean and disinfect
tubing, nasal cannulas, masks etc.:	dispose

4.2 with change of the patient

humidifier (reusable):	dispose
humidifier (non-reusable):	dispose
holder for humidifier:	clean and disinfect
tubing, nasal cannulas, masks etc.:	dispose

5 Description of functions

5.1 General information

The ambient air is drawn through the coarse dust filter (located in the back of the device) into the unit. The air is used for both cooling the compressor and also for the generation of the oxygen product gas.

The compressed air passes the device inlet filter before it enters alternating the molecular sieve beds of the functional unit. Sieve bed A is supplied by inlet solenoid I1 and sieve bed B by inlet solenoid I2. Both outlet solenoids O1 and O2 vent the sieve beds A and B. The bound nitrogen is blown off through an exhaust muffler. The respectively inactive sieve bed is flushed with the product gas of the active sieve bed and is pre-charged at the end of each cycle with oxygen enriched air.

All solenoids are directly and microprocessor controlled driven from the control PCB.

The temperature sensing probe is located in the compressor compartment and releases at temperatures $>60^{\circ}\text{C}$.

The pressure in the oxygen reservoir is sensed by a pressure sensor and processed by the microprocessor.

The product gas passes through the multifunctional sensor that simultaneously determines volume flow and oxygen concentration by an ultrasound sensor system.

If the oxygen concentration of the product gas drops below 82 %, the oxygen status alarm will be generated.

If the oxygen concentration of the product gas drops below 60 %, the oxygen deficiency alarm will be generated.

The adjustable pressure regulator limits the outlet pressure to approx. 450 mbar.

5.2 Control PCB

Block diagram

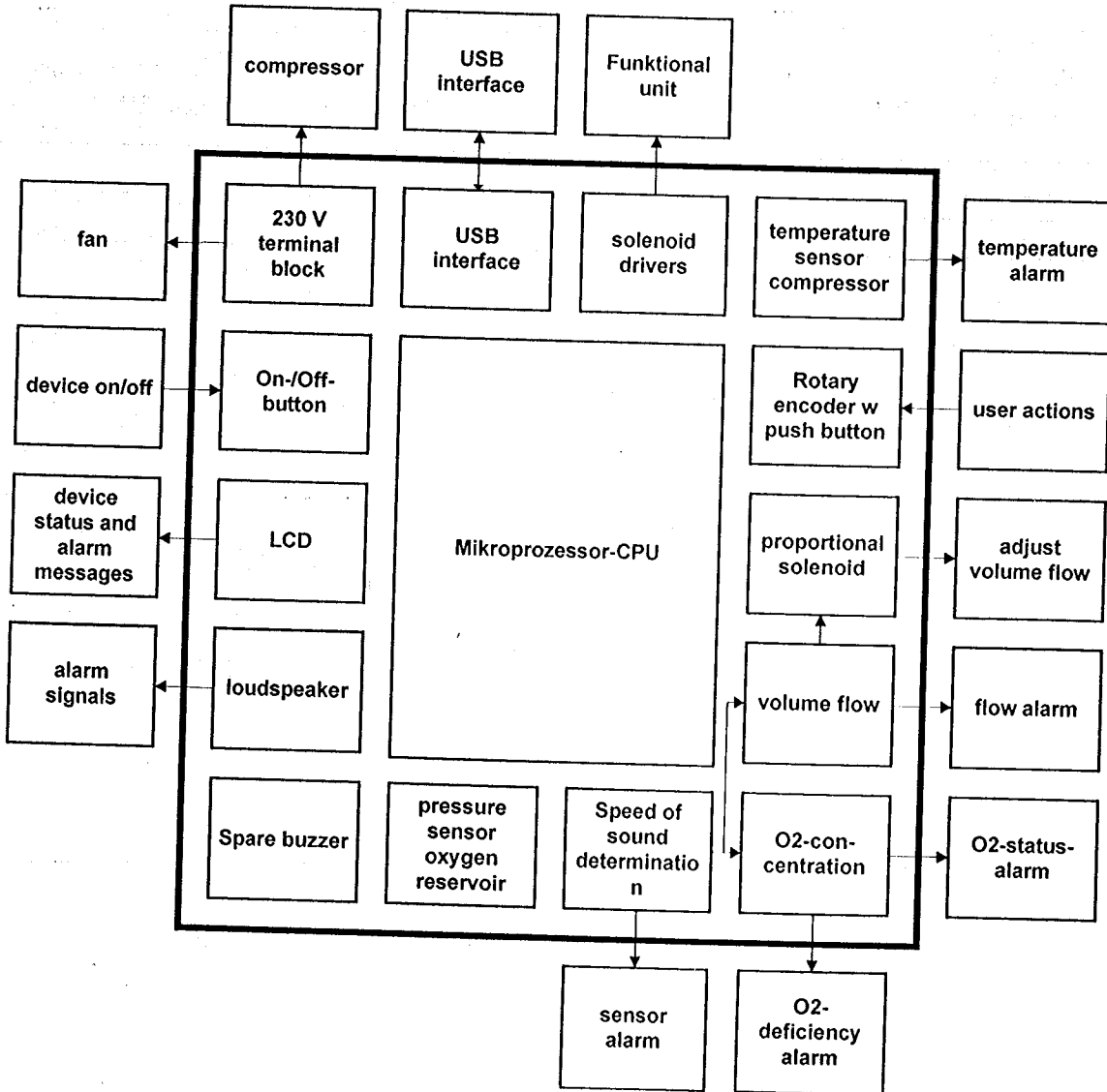

5.3 Flow schematics

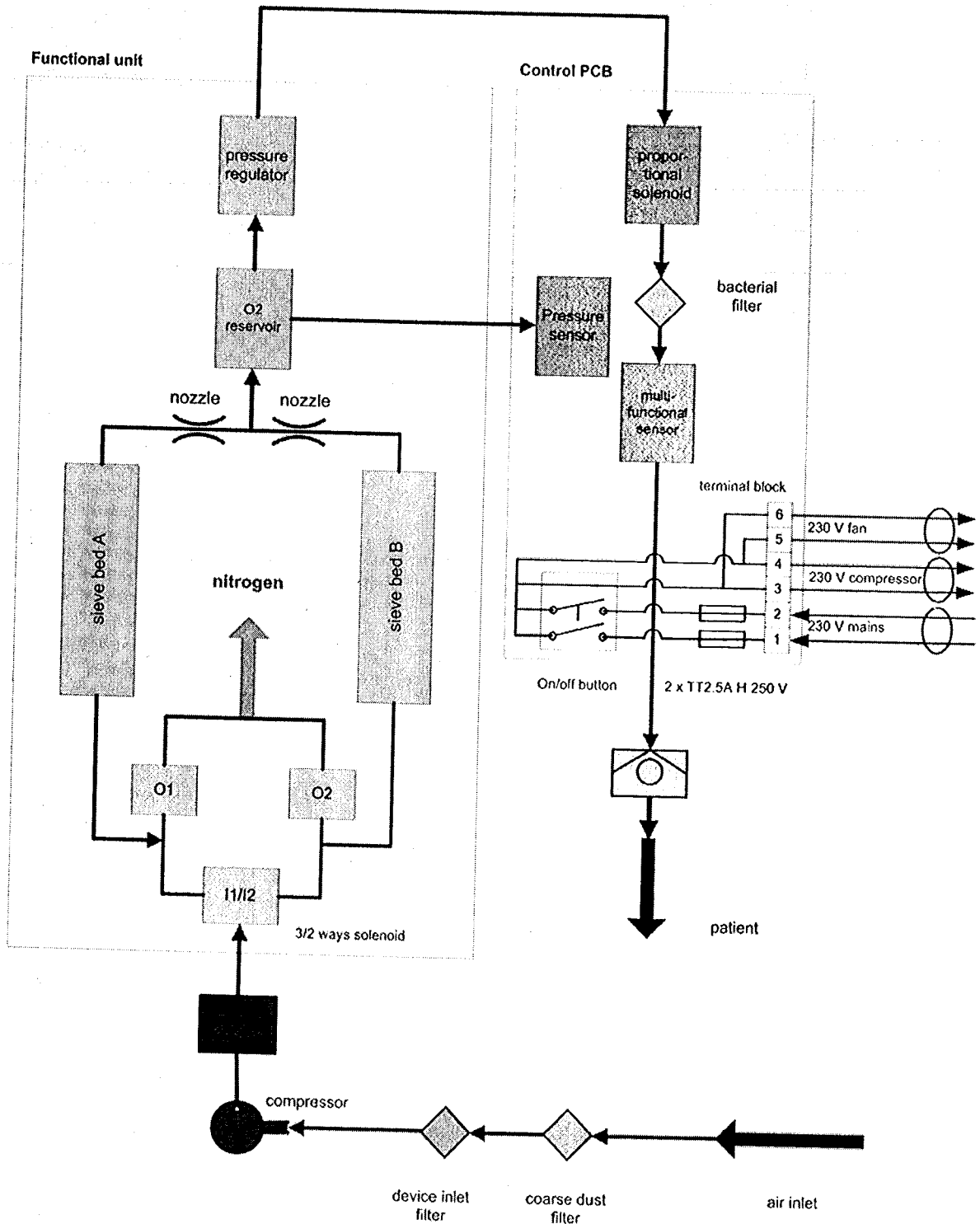

5.4 Alarms

5.4.1 Alarm priorities

We differentiate between three alarm priorities:

Alarm priority	Description
High priority:	 WARNING! Risk of health damage! Immediate countermeasures required to save the patient from any harm.
Medium priority:	Quick countermeasures by the user are required.
Low priority:	Utmost attention of the user is required.





NOTE!





The alarm priorities can audibly be differentiated by different alarm sound sequences. With a higher priority the number of alarm signals per unit of time increases.



Alarm priority	Alarm sound sequence
High priority:	2 x 5 pulses every 10 seconds
Medium priority:	3 pulses every 25 seconds
Low priority:	2 pulses, one-time

5.4.2 Alarm categories

Alarm category / LC display	Description
<p data-bbox="178 485 443 516">Temperature alarm</p> 	<p data-bbox="477 485 651 516">High priority</p> <p data-bbox="477 531 1309 569">The operating temperature inside the concentrator is above 60°C.</p> <p data-bbox="477 583 727 615">Countermeasures:</p> <ul style="list-style-type: none"> <li data-bbox="477 632 1075 663">– The unit should be switched off immediately. <li data-bbox="477 680 1332 779">– Check whether the air flow into the unit is restricted. Also make sure that the unit has a sufficient clearance to other objects (wall, cupboard, etc.). <li data-bbox="477 795 1097 827">– Check coarse dust filter. If congested: replace. <p data-bbox="511 856 681 909"> NOTE!</p> <p data-bbox="511 919 1226 989"><i>The oxygen supply is immediately stopped to protect the patient. However, the compressor keeps on running.</i></p> <ul style="list-style-type: none"> <li data-bbox="477 999 802 1031">– If fan defect: replace <li data-bbox="477 1047 1006 1079">– If compressor defect: replace or service

Description of functions





Alarm category / LC display	Description
<p>Mains failure alarm</p> 	<p>Hohe Priorität</p> <p>Die Stromversorgung des Geräts ist unterbrochen. Dies führt zum sofortigen Funktionsausfall des Kröber O2!</p> <p>Countermeasures</p> <p>The following should be checked:</p> <ul style="list-style-type: none"> - Is the mains lead properly plugged into the socket? - Has a fuse tripped? Check the fuse, replace if necessary. - Is the On/off button defect ? – Replace control PCB. - Defect in the cabling ? –Check cabling with opened unit. <p>Note</p> <p>If a function test concerning the mains failure alarm is to be performed, you should proceed as follows:</p> <ul style="list-style-type: none"> - Pull the mains plug out of the socket. - Switch on the unit. <p>The alarm works, if it is activated during the switch-on self-test.</p> <p> NOTE!</p> <p><i>If the alarm is triggered again after switching on, you should inform the service department.</i></p> <p> NOTE!</p> <p><i>The mains failure alarm is supplied by an internal maintenance-free capacitor.</i></p>
<p>Lack of oxygen alarm</p> 	<p>High priority</p> <p>The oxygen concentrator Kröber O2 is equipped with an innovative multi-function sensor to monitor the oxygen concentration of the oxygen output.</p> <p>If this drops below 60%, the lack of oxygen alarm is triggered.</p> <p>Countermeasures</p> <ul style="list-style-type: none"> - Check humidifier and hoses for leaks - Replace functional

Alarm category / LC display	Description
<p>Oxygen status alarm</p> 	<p>Low priority</p> <p>The oxygen concentrator Kröber O2 is equipped with an innovative multi-function sensor to monitor the oxygen concentration of the oxygen output.</p> <p>If this drops below 82%, the oxygen status alarm is triggered.</p> <p>Countermeasures</p> <ul style="list-style-type: none"> - Check humidifier and hoses for leaks - Replace functional unit
<p>Sensor alarm</p> 	<p>Medium priority</p> <p>There is a malfunction of the multi-function sensor, quantity and concentration of oxygen cannot be determined with sufficient accuracy.</p> <p>Countermeasures</p> <ul style="list-style-type: none"> - Inform the customer service. - Check whether the accessories are correctly connected. - Replace control PCB.
<p>System alarm</p> 	<p>High priority</p> <p>Micro-processor fault.</p> <p>Countermeasures</p> <ul style="list-style-type: none"> - Replace control PCB.

Description of functions

Alarm category / LC display	Description
Volume flow alarm  The image shows a rectangular LC display. In the center, the number '5.0' is displayed in a large, bold, digital font. To the right of '5.0', the unit 'lpm' is shown in a smaller font. Below the '5.0', the word 'ERROR' is displayed in a smaller, all-caps font. The entire display area is surrounded by a grid of small dots, and there are some faint, radiating lines around the '5.0'.	Medium priority The actual volume flow does not match the setting. Countermeasures <ul style="list-style-type: none">- Check whether the oxygen hose is buckled or squeezed.- Check whether the accessories are correctly connected.- Replace control PCB.

5.5 Symbols

Symbol	Explanation
	Warning, consult instructions for use.
	Applied part type BF
	Degree of protection II
	Notified Body TÜV Rheinland
	Power On/Off